



Photography: Wenzel

SHOP AND OFFICE FITTINGS

TECHNAL SYSTEM AND FURNITURE







SHOP AND OFFICE FITTINGS, simple and sleek modular solutions for professional fittings



Architect: Beaurin Photography: Xavier Boymond

Technal System and Furniture, solutions for internal and external shop and office fittings

Technal shop and office fitting systems are comprehensive and cost-effective.

The two product families: Technal System and Furniture stand out thanks to their modularity and the ease with which they can be disassembled (without tooling).

The Technal System enables the creation of versatile facades, shop fronts, display stand partitions and room dividers.

The furniture offers solutions for shop windows, display cases, facades and other internal fittings.

The various different combinations and options mean that the proposed solutions are totally versatile and can be used to personalise each space.



SHOP AND OFFICE FITTINGS

Technal System and Furniture

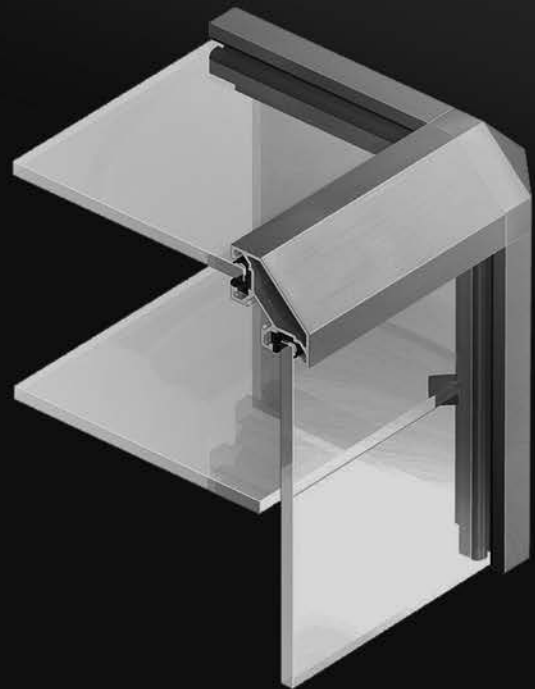

Features

Technal System

- Simplicity and versatility: ideal for creating facades without thermal breaks.
- Multiple solutions (thanks to the common 42 mm mounting groove): fixed windows, variable-angle or projecting facades, vestibules, etc.
- Personalised aesthetics: straight or curved design
- Various infill options (from 4 to 76.5 mm): glazing, wooden panels, composite materials, etc.
- Possibility of hinged and sliding doors for internal or external use.
- Possibility of incorporating special angles and multi-departing sections (from 2 to 8).

Furniture

- Modular and interchangeable solutions: simple installation of display cases, tables and desks without the need for tooling (thanks to the common 8 mm mounting groove).
- Easy installation due to the choice of straight or mitre-cut assembly.
- 2 designs for shop windows or facades: bevelled or straight.



SHOP AND OFFICE FITTINGS, Limitless design

Simplicity and multiple combinations

- Technical mounting groove common to all profiles.
- Assembly using self-locating junction blocks and corner cleats.
- Glass or wooden panel infills.
- Possible combination of profiles from different modules.
- Special angles and multi-departing sections.

Sleek finish

- Choice of profile lines: straight or bevelled.
- Finishing accessories: sockets, plugs, caps.

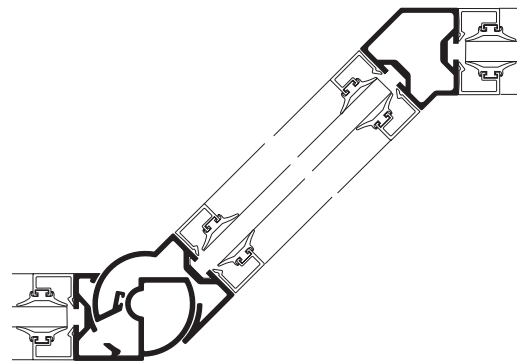

24 mm window module

- 1 module for 2 designs: flat and/or bevelled.
- Additional accessories: pivots, locks, etc



34 and 42 mm furniture module

- Modular, versatile, can be adjusted and taken to pieces.
- 8 mm technical groove for mounting accessories.
- Infills made from glass volumes, wooden panels, composite materials, etc.



SHOP AND OFFICE FITTINGS

Versatility and creative freedom

- 24 mm modular profiles.
- Quick and flawless assembly.
- Exposed accessories in the same colour as the profiles.



MA display case

- 2 oval section display cases: 200 x 84 mm, 132 x 56 mm.
- Additional accessories: stops, pivots, locks, etc.
- 12 mm technical groove for mounting accessories.



Decorative profiles

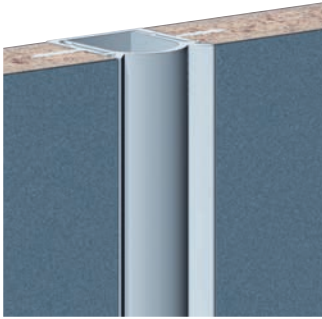

Panel junction

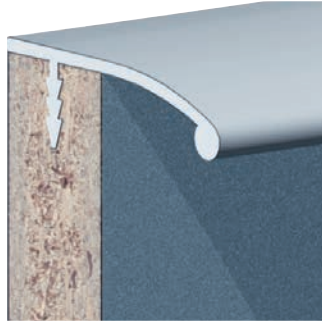

Wire handle

Display cases with roller track

- 1 or 2 rails with tracks, rollers and locks.



Sections

Furniture
Shop front with sliding door

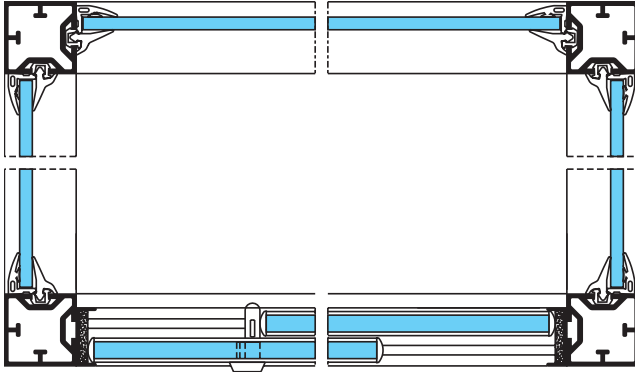

Outward-opening
hinged door

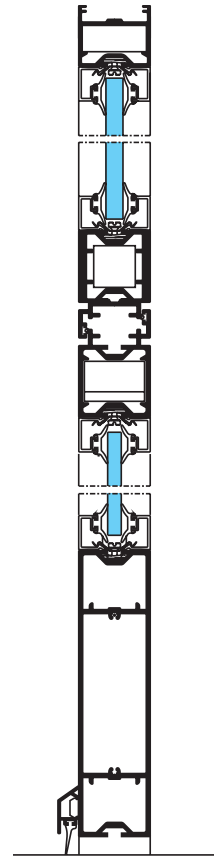

2-leaf door
on hinges

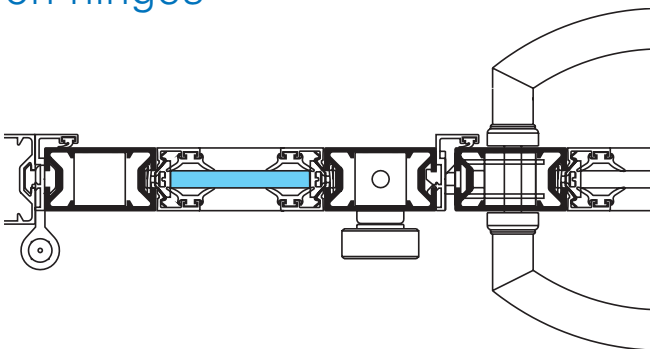

Technal System
Variable-angle facade

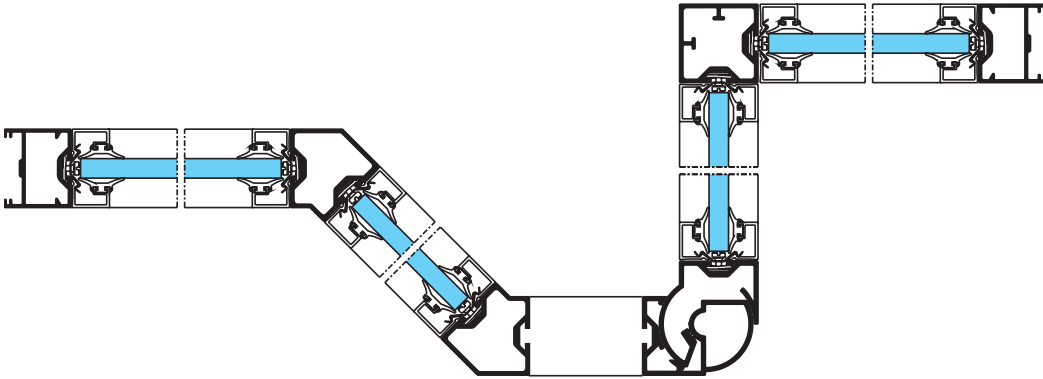

Applications

Shop fronts

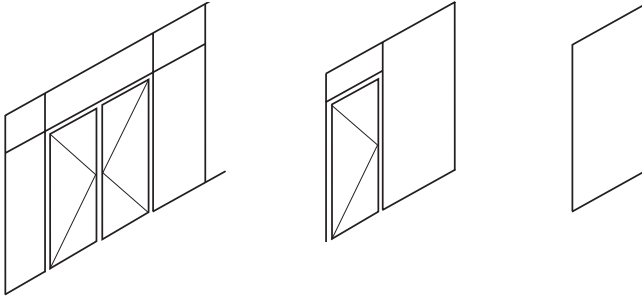

Faceted facades

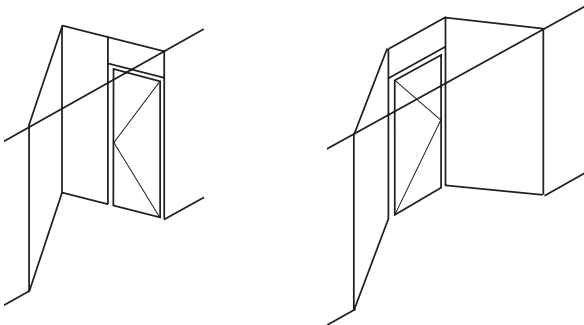

12

Furniture



MA module

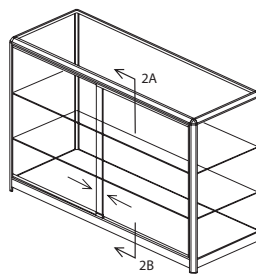

24 mm module

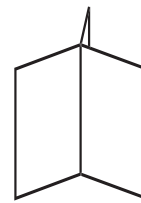

34 mm module

Installation

With a beaded frame
4 to 76.5 mm
depending on the module

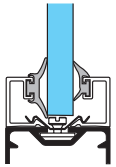

With gaskets
6 to 8 mm

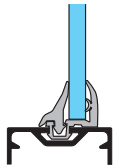

Directly onto the mounting groove
6 to 8 mm



24 mm structural profile
Installed directly without an infill gasket

12 mm



18 mm and above

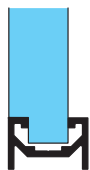

Reducer profile
4 to 6 mm glazing

4 to 6 mm

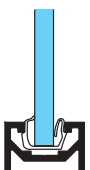

8 mm glazing

8 mm

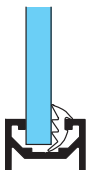





Photography: Wenzel

Materials and parts

As with all Technal systems, only the highest quality materials and components are used to minimise maintenance and ensure long-term performance.

- Aluminium profiles are extruded from 6060 T5 EN 12020, EN 573-3, EN 515 and EN 775-1 to 9 alloys.
- Fittings are cast from EN 12844 compliant Zamak 5.
- All gaskets are EPDM or TPE (Thermoplastic elastomer).
- The polyamide thermal breaks are extruded from pA6-6 (0.25 FV).
- Screws are made from stainless steel.

Finishes and colours

A wide range of finishes and colours is available to meet individual project requirements, enhancing existing buildings and offering architects and designers greater design freedom:

- Natural anodised in accordance with EN 123731: 2001.
- Polyester powder coating finishes in a wide range of colours in accordance with "QUALICOAT".
- The TECHNAL SYSTEM is also available in lacquered finishes with exclusive Technal colours for a stylish and contemporary look.





1



2



3

- 1. Photography: Xavier Boymond
- 2. Architect: P. de Fouchier Photography: Luc Boegly
- 3. Photography: Wenzel

270, rue Léon-Joulin
BP 63709 - 31037 Toulouse cedex 1 - FRANCE
Tel. +33 5 61 31 28 28 - www.technal.com



The world looks better

